

Nickel(0)-Catalyzed [2 + 2] Annulation of Electron-Deficient Allenes. Highly Regioselective Synthesis of Cyclobutanes

Shinichi Saito,^{*,†} Kyoko Hirayama,[‡] Chizuko Kabuto,[‡] and Yoshinori Yamamoto^{*,‡}

Contribution from the Institute for Chemical Reaction Science and the Department of Chemistry, Graduate School of Science, Tohoku University, Sendai 980-8578, Japan

Received June 22, 2000

Abstract: The nickel-catalyzed [2 + 2] annulations of electron-deficient allenenes proceed efficiently in a highly regioselective manner under very mild conditions to give the head-to-head cyclodimerization products, bismethylenecyclobutanes, as single isomers in good to fair yields. We also carried out the stoichiometric reaction of these allenenes in the presence of Ni(0) complexes and elucidated the mechanism of this highly selective reaction.

Though the thermal [2 + 2] annulation of allenenes (1,2-dienes) leading to bismethylenecyclobutanes has been investigated extensively, the reported regioselectivity of the reactions is low. In most cases the cyclobutanes are isolated as a mixture of isomers, and the synthetic usefulness of this reaction is highly restricted (eq 1).¹ On the other hand, the transition metal-

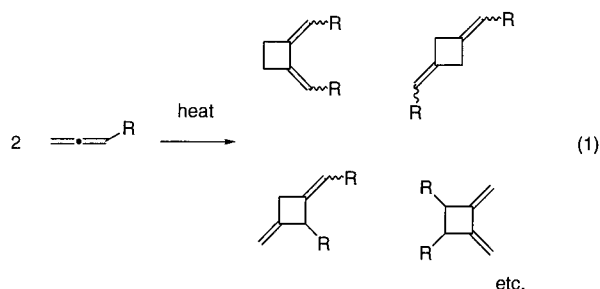

catalyzed cyclodimerization of allenenes and cumulenes has been investigated to much less of an extent,² and the formation of a mixture of cyclic dimers, trimers, oligomeric compounds, and polymers has been reported in the literature.³ The high selectivity of the reaction has been reported in a few examples in which a symmetric allene⁴ and cumulenes⁵ have been employed as the

substrates. Considering the usefulness of the four-membered carbocycles in organic synthesis,⁶ the development of the efficient synthetic method of cyclobutanes by this type of [2 + 2] reactions is very important.

Recently, we examined the transition-metal catalyzed dimerization of conjugated enynes and noticed that the reactivity and the mode of the reaction changed dramatically by the introduction of an electron-withdrawing group to the substrate.⁷ To explain the results we obtained, we proposed that the [2 + 2] reaction was induced by the introduction of the electron-withdrawing group to the enynes. However, it was not clear whether this type of [2 + 2] reaction is a very specific reaction, which would only be observed in the reaction of enynes, or if the [2 + 2] reaction of other electron-deficient hydrocarbons would be observed in general. On the basis of the hypothesis that the [2 + 2] reaction of electron-deficient hydrocarbons would proceed efficiently in the presence of a Ni catalyst, we studied the reaction of some electron-deficient allenenes in the presence of transition metal catalysts. In this paper we report the highly regioselective [2 + 2] annulation of electron-deficient allenenes in the presence of Ni(0) catalysts (eq 2).

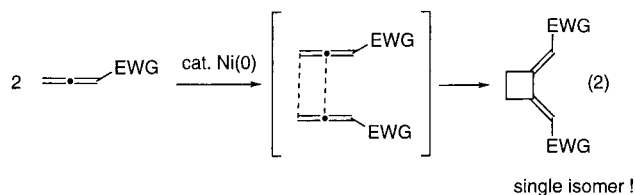

Results

Ni(PPh₃)₄-Catalyzed [2 + 2] Reaction of Electron-Deficient Allenenes. Perfluorohexylallene (**1a**) cyclodimerized in the pres-

(4) Ingrosso, G.; Iqbal, M.; Rossi, R.; Porri, L. *Chim. Ind. (Milan)* **1973**, 55, 540.

(5) (a) Iyoda, M.; Tanaka, S.; Nose, M.; Oda, M. *J. Chem. Soc., Chem. Commun.* **1983**, 1058–1059. (b) Iyoda, M.; Tanaka, S.; Otani, H.; Nose, M.; Oda, M. *J. Am. Chem. Soc.* **1988**, 110, 8494–8500. (c) Iyoda, M.; Kuwatani, Y.; Oda, M. *J. Am. Chem. Soc.* **1989**, 111, 3761–3762.

(6) Belluš, D.; Ernst, B. *Angew. Chem., Int. Ed. Engl.* **1988**, 27, 797–827.

(7) Saito, S.; Tanaka, T.; Koizumi, T.; Itagaki, H.; Kawasaki, T.; Endo, S.; Yamamoto, Y. *J. Am. Chem. Soc.* **2000**, 122, 1810–1811.

[†] Institute for Chemical Reaction Science.

[‡] Department of Chemistry.

(1) Reviews: (a) Schuster, H. F.; Coppola, G. M. *Allenenes in Organic Synthesis*; Wiley: New York, 1984; Chapter 9, pp 286–330. (b) Pasto, D. J. *Tetrahedron* **1984**, 40, 2805–2827. (c) Jolly, P. W. Nickel Catalyzed Oligomerization of Alkynes and Related Reactions. In *Comprehensive Organometallic Chemistry*; Wilkinson, G., Stone, F. G. A., Abel, E. W., Eds.; Pergamon: Oxford, 1982; pp 664–670.

(2) A small number of transition metal-catalyzed [2 + 2] reactions have been reported in the literature. See: Lautens, M.; Klute, W.; Tam, W. *Chem. Rev.* **1996**, 96, 49–92. Schore, N. E. *Chem. Rev.* **1988**, 88, 1081–1119.

(3) (a) Ohtsuka, S.; Mori, K.; Imaizumi, F. *J. Am. Chem. Soc.* **1965**, 85, 3017–3019. (b) Ohtsuka, S.; Mori, K.; Suminoe, T.; Imaizumi, F. *Eur. Polym. J. Chem.* **1967**, 3, 73–83. (c) Ohtsuka, S.; Nakamura, A.; Tani, K.; Ueda, S. *Tetrahedron Lett.* **1969**, 5, 297–300. (d) Hoover, F. W.; Lindsey, R. V., Jr. *J. Org. Chem.* **1969**, 34, 3051–3052. (e) De Pasquale, R. J. *J. Organomet. Chem.* **1971**, 32, 381–393. (f) Otsuka, S.; Tani, K.; Yamagata, T. *J. Chem. Soc., Dalton Trans.* **1973**, 2491–2497. (g) Pasto, D. J.; Huang, N.-Z.; Eigenbrot, C. W. *J. Am. Chem. Soc.* **1985**, 107, 3160–3172. (h) Pasto, D. J.; Huang, N.-Z.; Eigenbrot, C. W. *Organometallics* **1985**, 4(8), 1386–1395. (i) Takagi, K.; Tomita, I.; Endo, T. *Macromolecules* **1998**, 31, 6741–6747, and references therein.

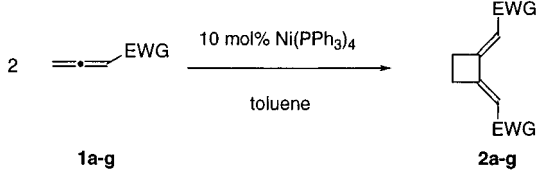
Table 1. Nickel(0)-Catalyzed [2 + 2] Annulation of Allenes

entry	EWG	conditions	yield of 2 (%)
1	<i>n</i> -C ₆ F ₁₃ (1a)	rt, 30 min	79
2	<i>n</i> -C ₆ F ₁₃ (1a)	rt, 30 min ^a	79
3	<i>n</i> -C ₆ F ₁₃ (1a)	rt, 30 min ^b	72
4	C ₆ F ₅ (1b)	rt, 30 min	81
5	COOEt (1c)	-15 to -10 °C, 30 min	71
6	CON(Me)Ph (1d)	0 °C, 2 h ^c	66
7	COEt (1e)	-15 to -10 °C, 3 h ^d	34
8	COPh (1f)	-15 to -10 °C, 1.5 h ^e	36
9	SO ₂ Ph (1g)	rt, 1.5 h ^e	33

^a The catalyst was prepared from (PPh₃)₂NiBr₂ (10 mol %), PPh₃ (20 mol %), and Zn dust (100 mol %). See ref 5b. ^b The reaction was carried out in the presence of Ni(cod)₂ (10 mol %) and PPh₃ (20 mol %). ^c A smaller amount (20 mol %) of PPh₃ was used. ^d The substrate was added slowly to a solution of catalyst for 1 h, and the mixture was stirred for 2 h. ^e The substrate was added slowly to a solution of catalyst for 1 h, and the mixture was stirred for 30 min.

ence of a catalytic amount of Ni(PPh₃)₄ (10 mol %), which was prepared in situ from Ni(cod)₂ and PPh₃, to give the [2 + 2] cycloadduct **2a** in 79% yield (Table 1, entry 1). The reaction proceeded in a highly regioselective manner, and we could not isolate other isomeric cyclobutanes. This reaction also proceeded smoothly when the Ni(0) catalyst was prepared from a stable Ni(II) complex, (PPh₃)₂NiBr₂, PPh₃, and Zn dust (entry 2).^{5b} In the presence of Ni(cod)₂ (10 mol %) and a smaller amount of PPh₃ (20 mol %), the yield of **2a** was slightly lower (entry 3). We found that the scope of this reaction is very wide, and the reaction of allenes substituted with other electron-withdrawing groups also proceeded smoothly (Table 1). Thus, the reaction of pentafluorophenylallene (**1b**) gave the corresponding cyclobutane **2b** in 81% yield (entry 4). Allenyl ester **1c** also cyclodimerized efficiently to give the corresponding cyclobutane derivative **2c** in 71% yield (entry 5). Allenyl amide **1d**, which is a less electron-poor allene compared to **1a–c**, was also sufficiently reactive, giving the cyclodimerized product (entry 6). Ketoallene **1e** also dimerized to give the corresponding cyclobutane **2e** in low yield (entry 7). Though we assumed that the presence of an acidic α -proton in **1e** resulted in the lower yield of **2b** and carried out the reaction of **1f**, the yield of the product did not increase (entry 8). Even sulfonyllallene **1g** cyclodimerized in the presence of Ni(0) catalyst (entry 9).⁸ It is noteworthy that the reaction of 1-hexylallene (1,2-nonadiene) resulted in the formation of a complex mixture which is composed of oligomeric compounds.⁹ Therefore, the existence of an electron-withdrawing group is essential for the [2 + 2] reaction to proceed efficiently in a highly regioselective manner. Furthermore, the choice of the catalyst is very important, and this reaction did not proceed in the presence of Pd(0) or Pt(0) catalysts.

We also studied the reaction of disubstituted allenes, though no satisfactory result was obtained. Thus, the reaction of **3** (eq 3) did not proceed in the presence of Ni(0) catalyst at elevated

(8) We assume that the yields of the products in entries 7–9 were low because of the formation of polymeric compounds. We could not isolate isomeric cyclobutanes from the reaction mixtures.

(9) We assume that the oligomeric compounds were formed in this reaction since the formation of oligomeric compounds has been reported in the Ni(0)-catalyzed reaction of ethylallene under quite similar conditions. See, ref 3g.

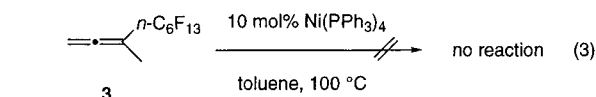

temperatures, while the reaction of **4** resulted in the formation of a complex mixture at room temperature (eq 4).

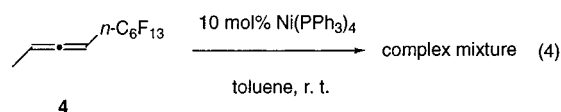

The structure of the cycloadduct was confirmed by an X-ray crystallographic analysis.¹⁰ The formation of the 1,2-bis(methylene)cyclobutane and the regiochemistry of the double bonds were unambiguously confirmed. It is noteworthy that the substituents (electron-withdrawing groups) of **2** were oriented in an outward direction. The observed tendency is in sharp contrast to the observed general preference for the orientation in an inward direction in the thermal dimerization of allenes.¹

Ni(0)-Mediated Dimerization of Electron-Deficient Allenes. When we examined effects of the bidentate ligands on the Ni(0)-catalyzed [2 + 2] reaction of allenes, we observed the formation of acyclic dimeric compounds. The catalytic reaction did not proceed in the presence of bidentate ligands, and we assumed that the reaction stopped in the middle of the catalytic cycle of the [2 + 2] reaction. To study the mechanism of the [2 + 2] reaction, we carried out the reaction of allenes in the presence of a stoichiometric amount of Ni(0) complexes.

Perfluorohexylallene (**1a**) reacted in the presence of 1 equiv of Ni(cod)₂-DPPP to give the dimeric compound **5** in 38% yield (eq 5).¹¹ It is noteworthy that the elimination of the fluoride

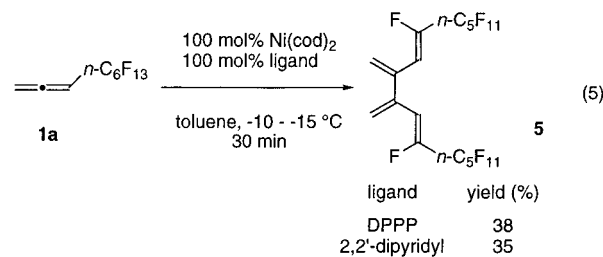

anion at the allylic position of **1a** occurred along with the C–C bond formation. The same reaction proceeded when the reaction was carried out in the presence of Ni(cod)₂-2,2'-dipyridyl. The observed result is in sharp contrast to the result of the reactions in the presence of Ni(PPh₃)₄.

To prevent the elimination reaction from occurring, we carried out the reaction of allenyl ester **1c** in the presence of Ni(cod)₂-DPPP (1 equiv). In this reaction, an elimination reaction was not observed, and compound **6** was formed by the reductive dimerization of **1c** (eq 6). The same reaction proceeded when the reaction was carried out in the presence of Ni(cod)₂-2,2'-dipyridyl.¹¹

Discussion

Substituent Effects on the Nickel-Catalyzed Reaction of Allenes.

As shown in our study, the presence of the electron-

(10) Crystallographic data for **2b**: MF = C₁₈H₆F₁₀, MW = 412.23, triclinic; *a* = 12.691(4), *b* = 13.396(3), and *c* = 4.9319(8) Å, α = 92.45-(2)°, β = 97.63(2)°, γ = 70.22(2)°, *V* = 782.0(3) Å³, space group *P1* (No. 2), *Z* = 2, *D*_c = 1.751 g/cm³. Data collection was done using Mo–K α radiation (μ = 1.85 cm⁻¹) with a rotating anode diffractometer (45 kV, 200 mA). A total of 3203 reflections was collected, of which 1580 reflections with *I*_o > 3 σ (*I*_o) were used in the refinement. The final *R* factor was 0.045 (*R*_w = 0.040). The final difference peaks were ρ_{\max} = 0.15 and ρ_{\min} = -0.13 e/Å³. For details, see the Supporting Information.

(11) The formation of oligomeric compounds was also observed in these stoichiometric reactions.

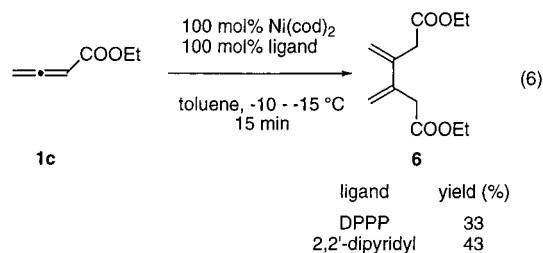

withdrawing group is essential for the [2 + 2] reaction to proceed efficiently. Pasto et al. reported the formation of a mixture of cyclic oligomers in the Ni(0)-catalyzed reaction of monosubstituted allenes such as ethylallene and *tert*-butylallene, and the result could be explained in terms of the facile insertion of the allene to the nickelacyclopentane intermediate.^{3g} We also carried out the Ni(0)-catalyzed reaction of hexylallene and observed the formation of a complex mixture which would be composed of oligomeric compounds. On the basis of these results, we assume that the initial formation of the C–C bond proceeds efficiently even in the absence of the electron-withdrawing group. The substituent (electron-withdrawing group) would induce the regioselective interaction (coordination) of the Ni complex with the allenic moiety and also enhance the reductive elimination of the Ni species from the intermediate (vide infra).

Unlike the Ni(0)-catalyzed zipper annulation of conjugated enynes,⁷ the [2 + 2] reaction of allenes proceeded efficiently in the presence of a wide range of electron-withdrawing groups such as alkoxy carbonyl groups as well as the perfluorohexyl group, and the difference of the electronic properties (inductive/field effect vs resonance effect) of the substituent did not affect the mode of the reaction. This result could be explained in terms of the small influence of the resonance effect on the reactive double bond of the allene. Thus, the formation of the C–C bonds between the “terminal” double bonds was observed, and these reactive π bonds were not affected by the resonance effect of the substituents attached to the allene, because the π bonds are perpendicular to each other.¹²

Structure of the Intermediates in the [2 + 2] Reaction.

Though we did not succeed in the isolation of the intermediates of the [2 + 2] reaction, we elucidated the structure of the intermediates on the basis of the results of the stoichiometric reactions of Ni(0) complexes with allenes. The following discussion is based on the assumption that the mode of the coordination of the Ni complex does not change by using a bidentate ligand instead of a monodentate ligand.

It is well-known that 2 equiv of allenes react with 1 equiv of Ni(0) complexes, and the structure of the product has been analyzed by an X-ray crystallographic analysis. Thus, Jolly et al. reported the formation of the nickelacyclopentane **7** by the reaction of allene (1,2-propadiene) with Ni(cod)₂ and DPPE (eq 7).¹³ It is noteworthy that the C–C bond was formed between

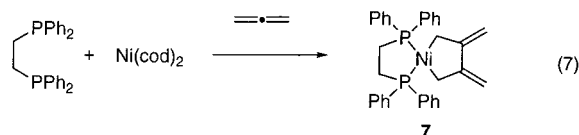

(12) On the other hand, the resonance effect plays an important role in the reaction of conjugated enynes. See, ref 7 and Saito, S.; Tsuboya, N.; Chouman, Y.; Nogami, T.; Yamamoto, Y. *Tetrahedron Lett.* **1999**, *40*, 7529–7532.

(13) Jolly, P. W.; Krüger, C.; Salz, R.; Sekutowski, J. C. *J. Organomet. Chem.* **1979**, *165*, C39–42.

Scheme 1

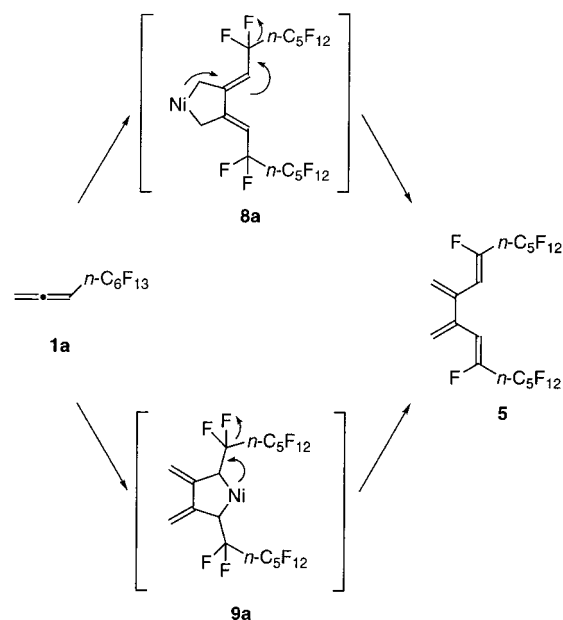

Scheme 2

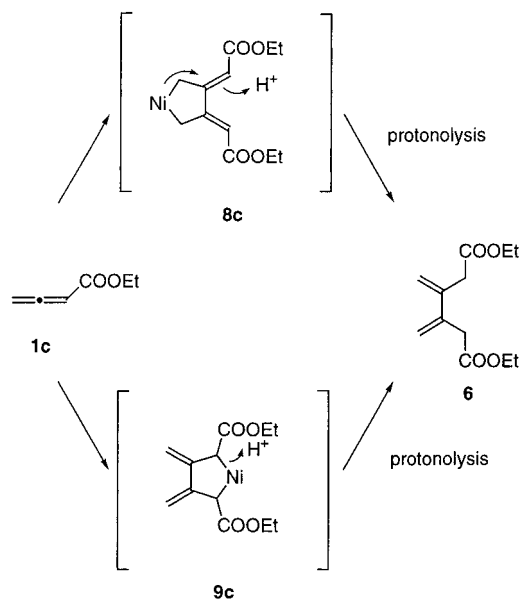

the internal *sp* carbon atoms, and we assume that a similar intermediate is formed in this [2 + 2] reaction. This assumption is supported by the isolation of dimerized compounds **5** and **6**, respectively, in the stoichiometric reaction of **1a** and **1c** with Ni(0)–bidentate ligand complexes: the formation of a C–C bond between the internal *sp* carbons was observed in these reactions. The formation of **5** could be explained in terms of the elimination of the fluoride anion from **8a** or **9a** (Scheme 1). The formation of **6** could also be explained in terms of the protonolysis of **8c** or **9c** during the workup (Scheme 2).¹⁴

Considering the electronic effects on the double bonds of the allene, the interaction between “bond B (internal double bond)” and the Ni(0) species would be stronger than that between the “bond A (external double bond)” and the Ni(0) species, and the formation of complex **9** is more likely (Scheme 3).¹⁵ In fact, compound **9** might be formed as a kinetically favored intermediate. However, considering the steric effect, complex **8** would

(14) Benn, R.; Jolly, P. W.; Mynott, R.; Schenker, G. *Organometallics* **1985**, *4*, 1136–1138.

Scheme 3

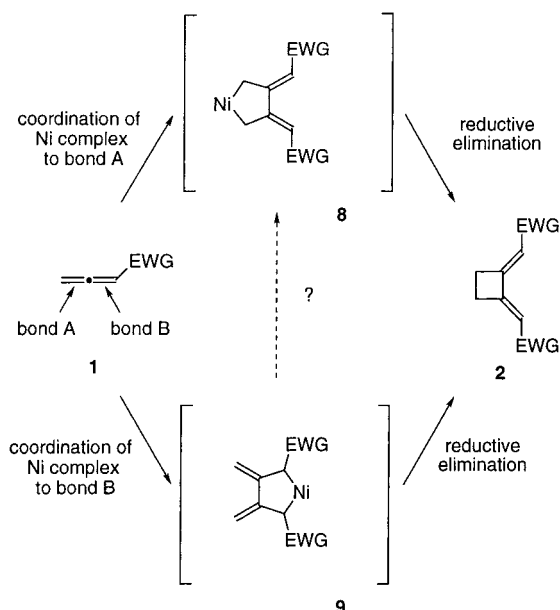

Scheme 4

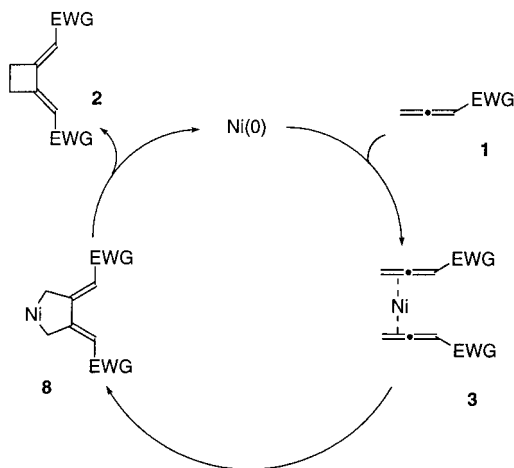

be a more stable intermediate, and the reductive elimination of the Ni(0) species from **8** would be more easily understood. The poor alignment of the π orbitals of the two C=C bonds in complex **9** would prevent the cyclization (C-C bond formation) from occurring, and if complex **9** was formed as an intermediate, it would isomerize to **8** and undergo subsequent reactions. On the basis of the strong influence of the steric factor on this [2 + 2] reaction which we observed in the reactions of polysubstituted allenes (eqs 3 and 4), we assume that compound **8** would be the reactive intermediate of the reaction.

Mechanism of the [2 + 2] Reaction. Currently we assume that the reaction would proceed as shown in Scheme 4. The reaction of **1** with Ni(0) species would regioselectively produce the nickelacyclopentane **8** by the regioselective coordination of allenes followed by C-C bond formation,¹⁶ and intermediate **8** would undergo quick reductive elimination to give cyclobutane **2** as the final product. The observed high regioselectivity of the reaction could be explained in terms of the regioselective

(15) The interaction of the analogous palladium(0) species with electron-deficient alkynes is much stronger than that with electron-rich alkynes. See: Greaves, E. O.; Lock, C. J. L.; Maitlis, P. M. *Can. J. Chem.* **1968**, *46*, 3879–3891, and references therein.

(16) These metallacycles are very popular intermediates in various transition metal-catalyzed reactions. See, ref 17.

Scheme 5

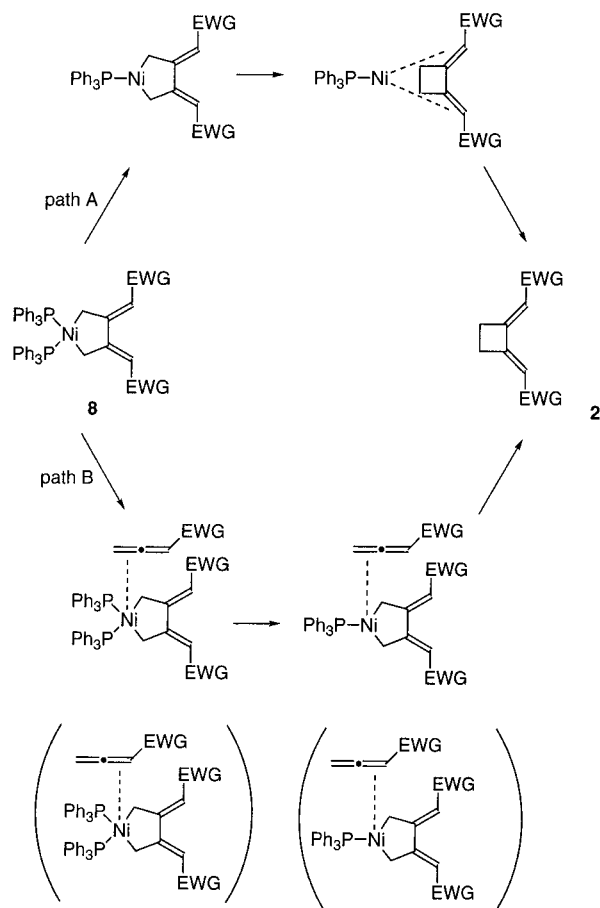

formation of metallacycle **8**, which would be controlled by the electronic and steric effects of the substituent of **1**.

The facile reductive elimination of the Ni(0) species from the five-membered metallacycle **8**, which is the most characteristic feature of this [2 + 2] reaction, would be promoted by the electron-withdrawing groups attached to the allenes. It is also noteworthy that the catalytic reaction does not proceed in the presence of bidentate ligands, indicating the dissociation of the ligand prior to the reductive elimination.^{18,19} There are two possible mechanistic pathways which account for this process (Scheme 5). Thus, the reductive elimination might take place by the simple dissociation of a ligand from complex **8** (path A) or by the precoordination of the allene, followed by the dissociation of the ligand and reductive elimination (path B). In the former case, the reductive elimination would be facilitated by the strong coordinating ability of the product **2**, and in the latter case, the reductive elimination would be promoted by the coordination of another electron-deficient allene molecule.²⁰ In both cases, the presence of the electron-withdrawing group attached to the allenes plays an important role in allowing this reaction to proceed. It is noteworthy that the reductive elimination of the metal complex from the metallacyclopentane has been observed in a limited number of *catalytic* reactions.^{2–5,21}

(17) Collman, J. P.; Hegedus, L. S.; Norton, J. R.; Finke, R. G. *Principles and Applications of Organotransition Metal Chemistry*; University Science Books: Mill Valley, CA, 1987; Section 11, pp 578–617.

(18) Dissociation of the ligands plays important roles in various Ni- and Pd-catalyzed reactions. For example, see: Hartwig, J. F. *Angew. Chem., Int. Ed.* **1998**, *37*, 2046–2067. Kawatsura, M.; Hartwig, J. F. *J. Am. Chem. Soc.* **1999**, *121*, 1473–1478.

(19) A referee has pointed out the possibility that the interconversion of **9** and **8** was blocked by the bidentate ligand.

(20) Similar examples have been reported in the literature. See ref 17, Section 5.6, pp 322–333.

Conclusion

Electron-deficient allenes cyclodimerized in a highly regioselective manner in the presence of a catalytic amount of Ni(PPh₃)₄ to yield bismethylenecyclobutanes under mild conditions. Our findings clearly demonstrate that the previously uncommon [2 + 2] type reactions of electron-deficient hydrocarbons such as conjugated enynes⁷ and allenes proceed under very mild conditions in the presence of nickel(0) complex. We are currently investigating the transition metal-catalyzed reactions of other electron-deficient hydrocarbons to examine the generality of this new concept.

Experimental Section

The syntheses of **1a**,²² **1b**,^{22,23} **1c**,²⁴ **1d**,²⁵ **1e**,²⁶ **1f**,^{26,27} **1g**,²⁸ **3**,²² and **4**²² were carried out according to the procedures reported in the literature.

General Procedure for the Reaction of Allenes in the Presence of Ni(0) Catalyst (Table 1). To a mixture of Ni(cod)₂ (28 mg, 0.1 mmol) and PPh₃ (105 mg, 0.4 mmol) in dry toluene (0.5 mL) was added a solution of allene **1** (1.0 mmol) in dry toluene (0.5 mL) under Ar. The mixture was stirred at the specified temperature (see Table 1) and filtered through a short alumina column. The filtrate was evaporated, and the residue was further purified by column chromatography (silica gel, hexane, or hexane–AcOEt) to give pure cyclobutane **2**.

1,2-Bis(2,2,3,3,4,4,5,5,6,6,7,7,7-tridecafluoroheptylidene)cyclobutane (2a): colorless oil; ¹H NMR (CDCl₃, 300 MHz) 5.82 (t, *J* = 13.9 Hz, 2H), 3.03 (bs, 4H); ¹³C NMR (CDCl₃, 75 MHz) 107.5–119.6 (m), 152.2, 108.7, 28.9; IR (neat) 2997, 2955, 1674, 1420, 1366, 1342, 1313, 1240, 1202, 1146, 1121, 1078, 1063, 978, 853, 814, 735 cm⁻¹. Anal. Calcd for C₁₈H₆F₂₆: C, 30.19; H, 0.84. Found: C, 30.25; H, 0.92.

1,2-Bis(2,3,4,5,6-pentafluorophenylidene)cyclobutane (2b): colorless needles (recrystallized from Et₂O–hexane), mp 133–135 °C; ¹H NMR (CDCl₃, 300 MHz) 6.57 (s, 2H), 2.85 (s, 4H); ¹³C NMR (CDCl₃, 75 MHz) 149.8, 144.4 (t, *J*_{C–F} = 246 Hz), 140.2 (t, *J*_{C–F} = 254 Hz), 137.7 (t, *J*_{C–F} = 251 Hz), 111.0, 104.4, 29.0; IR (KBr) 2991, 2969, 2943, 1652, 1520, 1494, 1414, 1375, 1352, 1306, 1150, 1126, 1080, 1038, 1005, 970, 945, 929, 875, 853, 799, 722 cm⁻¹. Anal. Calcd for C₁₈H₆F₁₀: C, 52.45; H, 1.47. Found: C, 52.41; H, 1.76. HRMS: calcd for C₁₈H₆F₁₀ 412.0309, found 412.0282.

Ethyl (2-ethoxycarbonylmethylenecyclobutylidene)acetate (2c): colorless powder, mp 66–68 °C; ¹H NMR (CDCl₃, 300 MHz) 5.99 (s, 2H), 4.15 (q, *J* = 7.2 Hz, 4H), 3.08 (s, 4H), 1.25 (t, *J* = 7.2 Hz, 6H); ¹³C NMR (CDCl₃, 75 MHz) 166.0, 158.6, 112.1, 60.3, 30.6, 14.2; IR (KBr) 2983, 2946, 2909, 1711, 1692, 1648, 1476, 1448, 1370, 1338, 1231, 1217, 1187, 1124, 1034, 1016, 867, 818 cm⁻¹. Anal. Calcd for C₁₂H₁₆O₄: C, 64.27; H, 7.19. Found: C, 64.06; H, 7.31. HRMS: calcd for C₁₂H₁₆O₄ 224.1048, found 224.1037.

N-Methyl-2-{2-[(methylphenylcarbamoyl)methylene]cyclobutylidene}-N-phenylacetamide (2d): colorless powder, mp 166–168 °C; ¹H NMR (CDCl₃, 300 MHz) 7.14–7.27 (m, 6H), 7.01 (q, *J* =

7.0 Hz, 4H), 5.54 (s, 2H), 3.20 (s, 6H), 3.07 (s, 4H); ¹³C NMR (CDCl₃, 75 MHz) 165.7, 156.6, 143.5, 129.3, 127.2, 126.9, 11.0, 36.9, 30.9; IR (KBr) 2989, 2935, 1657, 1623, 1610, 1594, 1496, 1405, 1374, 1266, 1111, 834, 776, 703 cm⁻¹. HRMS: calcd for C₂₂H₂₂N₂O₂ 346.1680, found 346.1694.

1-[2-(2-Oxobutylidene)cyclobutylidene]butan-2-one (2e): pale yellow powder, mp 63–65 °C; ¹H NMR (CDCl₃, 300 MHz) 6.21 (s, 2H), 2.98 (s, 4H), 2.37 (q, *J* = 7.2 Hz, 4H), 0.90 (t, *J* = 7.2 Hz, 6H); ¹³C NMR (CDCl₃, 75 MHz) 200.3, 156.6, 118.1, 36.2, 31.3, 7.4; IR (KBr) 2982, 2938, 2900, 1684, 1616, 1456, 1404, 1363, 1333, 1117, 1042, 847 cm⁻¹. HRMS: calcd for C₁₂H₁₆O₂ 192.1149, found 192.1151.

2-[2-(2-Oxo-2-phenylethylidene)cyclobutylidene]-1-phenylethanol (2f): yellow needles (recrystallized from AcOEt–hexane), mp 138–140 °C; ¹H NMR (CDCl₃, 300 MHz) 7.97 (m, 4H), 7.53 (m, 6H), 7.29 (s, 2H), 3.31 (s, 4H); ¹³C NMR (CDCl₃, 75 MHz) 190.2, 160.7, 138.4, 132.9, 128.7, 128.1, 114.2, 32.4; IR (KBr) 2976, 2938, 1654, 1599, 1574, 1447, 1356, 1304, 1224, 1204, 1171, 1015, 989, 847, 780, 725 cm⁻¹. HRMS: calcd for C₂₀H₁₆O₂ 288.1149, found 288.1169.

1,2-Bis(Phenylsulfonylethylidene)cyclobutane (2g): colorless powder, mp 171–173 °C; ¹H NMR (CDCl₃, 300 MHz) 7.85 (q, *J* = 7.2 Hz, 4H), 7.50–7.65 (m, 6H), 6.43 (s, 2H), 3.22 (s, 4H); ¹³C NMR (CDCl₃, 75 MHz) 153.6, 140.7, 133.9, 129.4, 127.5, 123.3, 29.9; IR (KBr) 3097, 3040, 3027, 2947, 1630, 1446, 1324, 1307, 1147, 1083, 815 cm⁻¹. HRMS: calcd for C₂₀H₁₆O₂ 360.0489, found 360.0477.

General Procedure for the Ni(0)-Mediated Reaction of 1a in the Presence of Bidentate Ligands. To a mixture of Ni(cod)₂ (275 mg, 1.0 mmol) and ligand (1 mmol) in dry toluene (9.5 mL) was added a solution of allene **1a** (358 mg, 1.0 mmol) in dry toluene (0.5 mL) under Ar. The mixture was stirred at room temperature for 30 min and 2 N HCl aq. (10 mL) was added. The mixture was extracted with ether, and the combined organic layer was dried over MgSO₄ and evaporated. The residue was further purified by column chromatography (silica gel, hexane) to give pure tetraene **5**.

1,1,1,2,2,3,3,4,4,5,5,6,11,12,12,13,13,14,14,15,15,16,16,16-Tetracosafuoro-8,9-dimethylene-hexadeca-6,10-diene (5): colorless oil; ¹H NMR (CDCl₃, 300 MHz) 6.08 (d, *J* = 33.2 Hz, 2H), 5.54 (s, 2H), 5.47 (s, 2H), 2.85 (s, 4H); ¹³C NMR (CDCl₃, 75 MHz) 147.5 (t, *J*_{C–F} = 28.0 Hz), 143.9 (t, *J*_{C–F} = 27.9 Hz), 137.9, 119.1 (t, *J*_{C–F} = 32.9 Hz), 115.3 (t, *J*_{C–F} = 32.9 Hz), 113.3, 115–105 (m); IR (neat) 3103, 2934, 1690, 1362, 1352, 1238, 1204, 1160, 1144, 1112, 1078, 1002, 924, 873, 800, 733, 720 cm⁻¹. HRMS: calcd for C₁₈H₆F₂₄ 678.0085, found 678.0068.

General Procedure for the Ni(0)-Mediated Reaction of 1c in the Presence of Bidentate Ligands. To a mixture of Ni(cod)₂ (275 mg, 1.0 mmol) and ligand (1.0 mmol) in dry toluene (9.5 mL) was added a solution of allene **1c** (112 mg, 1.0 mmol) in dry toluene (0.5 mL) under Ar. The mixture was stirred at –10 to –15 °C for 15 min, followed by the addition of a mixture of water (10 mL) and THF (10 mL), and the mixture was further stirred for 15 min. The mixture was extracted with ether, and the combined organic layer was dried over MgSO₄ and evaporated. The residue was further purified by column chromatography (silica gel, hexane:AcOEt = 8:1) to give pure diene **6**.

3,4-Dimethylenehexanedioic acid diethyl ester (6): colorless oil; ¹H NMR (CDCl₃, 300 MHz) 5.27 (s, 2H), 5.15 (s, 2H), 4.12 (q, *J* = 7.2 Hz, 4H), 3.28 (s, 4H), 1.22 (t, *J* = 7.2 Hz, 6H); ¹³C NMR (CDCl₃, 75 MHz) 171.3, 139.5, 117.2, 60.8, 40.4, 14.1; IR (neat) 3098, 2983, 2938, 2906, 2875, 1738, 1732, 1602, 1465, 1447, 1426, 1392, 1367, 1324, 1262, 1178, 1097, 1035, 905, 851 cm⁻¹. HRMS: calcd for C₁₂H₁₈O₄ 226.1204, found 226.1207.

Acknowledgment. S.S. gratefully acknowledges financial support from Japan Securities Scholarship Foundation, Shimadzu Foundation, and Japanese Bioindustry Association.

Supporting Information Available: X-ray crystallographic data of **2b** and NMR spectra of **2a–g**, **5**, and **6**. This material is available free of charge via the Internet at <http://pubs.acs.org>.

JA002241C

(21) The further insertion of another molecule or the β-elimination of the hydride is more frequently observed in the catalytic reactions which involve five-membered metallacycles. See ref 17, Section 9, pp 459–520.

(22) (a) Burton, D. J.; Hartgraves, G. A.; Hsu, J. *Tetrahedron Lett.* **1990**, *31*, 3699–3702. (b) Hung, M.-H. *Tetrahedron Lett.* **1990**, *31*, 3703–3706.

(23) (a) Cairncross, A.; Sheppard, W. A.; Wonchoba, E. *Organic Syntheses*; Wiley: New York, 1973; Collect. Vol. VI, pp 875–882.

(24) Jung, M. E.; Nishimura, N. *J. Am. Chem. Soc.* **1999**, *121*, 3529–3530.

(25) Diehl, K.; Himbert, G.; Henn, L. *Chem. Ber.* **1986**, *119*, 2430–2443.

(26) Brandsma, L.; Verkruisje, H. D. *Synthesis of Acetylenes, Allenes and Cumulenes*; Elsevier: Amsterdam, 1981; Chapter 4, pp 101–102, and Chapter 8, p 236.

(27) Brandsma, L. *Preparative Acetylenic Chemistry*, 2nd ed.; Elsevier: Amsterdam, 1988; Chapter 3, p 67.

(28) Ma, S.; Wei, Q. *J. Org. Chem.* **1999**, *64*, 1026–1028.